



GP
ELECTRONICS

GPL6230 Series

Low Consumption Current High PSRR 300mA CMOS Voltage Regulators

Product Summary

The GPL6230 series are a group of positive voltage regulators manufactured by CMOS technologies with high ripple rejection, ultra-low noise, low power consumption and low dropout voltage, which can prolong battery life in portable electronics. The GPL6230 series work with low-ESR ceramic capacitors, reducing the amount of board space necessary for power applications. The GPL6230 series consume less than 0.1 μ A in shutdown mode and have fast turn-on time less than 50 μ S. The series are very suitable for the battery-powered equipments, such as RF applications and other systems requiring a quiet voltage source.

Features

- Low Quiescent Current: 5 μ A
- Operating Voltage Range: 2.0V~7.0V
- Low Dropout Voltage: 150mV@150mA
- Output Voltage: 1.2~ 5.0V
- High Accuracy: $\pm 2\%$ (Typ.)
- High Ripple Rejection: 65dB@1kHz
- TTL-Logic-Controlled Shutdown Input
- Excellent Line and Load Transient Response
- Built-in Current Limiter, Short-Circuit Protection

Applications

- Cellular and Smart Phones
- Radio control systems
- Laptop, Palmtops and PDAs
- Digital Still and Video Cameras
- Battery-Powered Equipment

Block Diagram

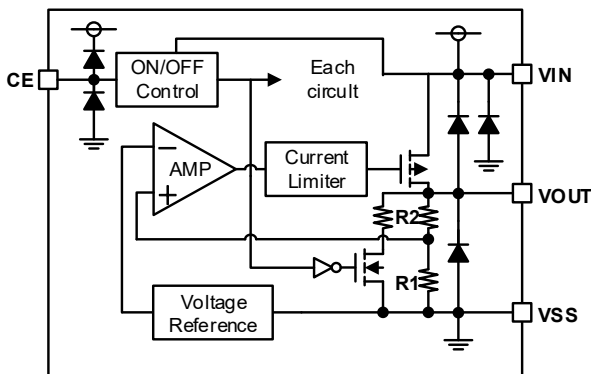

Order Information

GPL6230V①②

Designator	Description
①	Output Voltage e.g. 1.8V=18
②	Package: SOT-23-3L=K3 SOT-23-5L=K5 DFN1*1-4=H1 SOT-89-3L=KE SOT-89-5L=KT

Pin Configuration

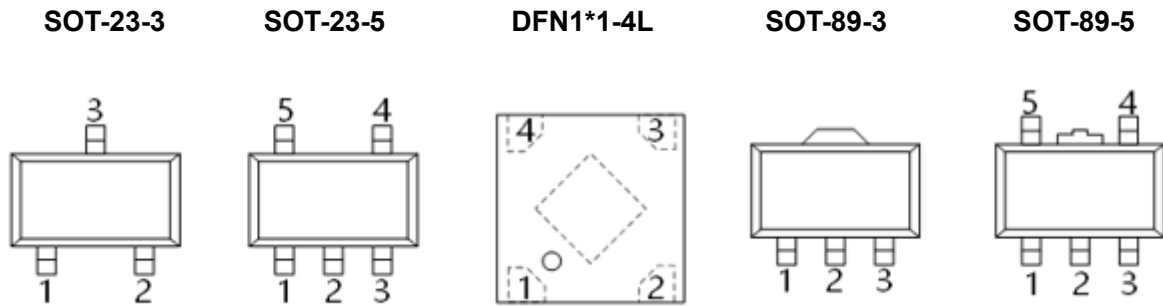

SOT-23-3L

Pin Number	Pin Name	Function
1	V_{SS}	Ground
2	V_{OUT}	Output
3	V_{IN}	Power input

SOT-23-5L

Pin Number	Pin Number	Function
1	V_{IN}	Power Input Pin
2	V_{SS}	Ground
3	CE	Chip Enable Pin
4	NC	No Connection
5	V_{OUT}	Output Pin

SOT-89-3L

Pin Number	Pin Number	Function
1	V_{SS}	Ground
3	V_{OUT}	Output
2	V_{IN}	Power input

SOT-89-5L

Pin Number	Symbol	Function
1	V_{OUT}	Output Pin
2	V_{SS}	Ground
3	NC	No Connection
4	CE	Chip Enable Pin
5	V_{IN}	Power Input Pin

Absolute Maximum Ratings ($T_A=25^{\circ}\text{C}$, unless otherwise noted)

Parameter	Symbol	Ratings	Units	
Input Voltage	V_{IN}	$V_{SS}-0.3 \sim V_{SS}+8$	V	
Output Voltage	V_{OUT}	$V_{SS}-0.3 \sim V_{IN}+0.3$	V	
Output Current	I_{OUT}	300	mA	
Power Dissipation	SOT-23	P_D	0.25	W
	SOT-89	P_D	0.50	W
Operating Free Air Temperature Range	T_A	-40~85	$^{\circ}\text{C}$	
Operating Junction Temperature Range	T_j	-40~125	$^{\circ}\text{C}$	
Storage Temperature	T_{stg}	-40~125	$^{\circ}\text{C}$	
Lead Temperature(Soldering, 10 sec)	T_{solder}	260	$^{\circ}\text{C}$	

Electrical Characteristics($V_{IN}=V_{OUT}+1\text{V}$, $C_{IN}=C_{OUT}=1\mu\text{F}$, $T_A=25^{\circ}\text{C}$, unless otherwise specified)

Parameter	Symbol	Conditions	Min.	Typ.	Max.	Units
Output Voltage	$V_{OUT(E)}^{1)}$	$I_{OUT}=1\text{mA}$	$V_{OUT} * 0.98$	V_{OUT}	$V_{OUT} * 1.02$	V
Supply Current	I_{SS}	$I_{OUT}=0$		5	10	μA
Standby Current	I_{STBY}	$CE = V_{SS}$			0.1	μA
Output Current	I_{OUT}	—	300			mA
Dropout Voltage ²⁾	V_{dif}	$I_{OUT} = 150\text{mA}, V_{OUT} \geq 3.0\text{V}$		150		mV
Load Regulation	ΔV_{OUT}	$V_{IN} = V_{OUT} + 1\text{V}$, $1\text{mA} \leq I_{OUT} \leq 100\text{mA}$		10		mV
Line Regulation	$\frac{\Delta V_{OUT}}{V_{OUT} \times \Delta V_{IN}}$	$I_{OUT} = 10\text{mA}$ $V_{OUT} + 1\text{V} \leq V_{IN} \leq 6\text{V}$		0.01	0.2	%/V
Output Voltage Temperature Characteristics	$\frac{\Delta V_{OUT}}{\Delta T \times V_{OUT}}$	$I_{OUT} = 10\text{mA}$ $-40 \leq T \leq +85$		100		ppm
Output Current Limit	I_{LIM}	$V_{OUT}=0.5 \times V_{OUT(\text{Normal})}$, $V_{IN} = V_{OUT}+1\text{V}$	350	700		mA
Short Current	I_{Short}	$V_{OUT} = V_{SS}$		50		mA
Input Voltage	V_{IN}	—	2.0		7.0	V
Power Supply Rejection Rate	1kHz	$I_{OUT}=50\text{mA}$		65		dB
	10kHz			50		
CE "High" Voltage	$V_{CE"High"}$		1.5		V_{IN}	V
CE "Low" Voltage	$V_{CE"Low"}$				0.3	V

- $V_{OUT(E)}$: Effective Output Voltage (i.e. The output voltage when $V_{IN} = (V_{OUT} + 1.0\text{V})$ and maintain a certain I_{OUT} Value).
- V_{dif} : The Difference Of Output Voltage And Input Voltage When Input Voltage Is Decreased Gradually Till Output Voltage Equals To 98% Of V_{OUT} (E).

Typical Application

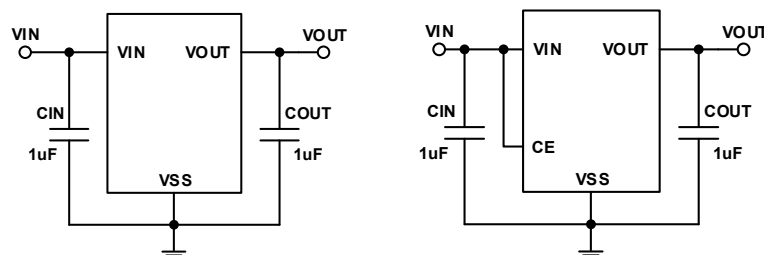

Typical Performance Characteristics

Output Characteristics

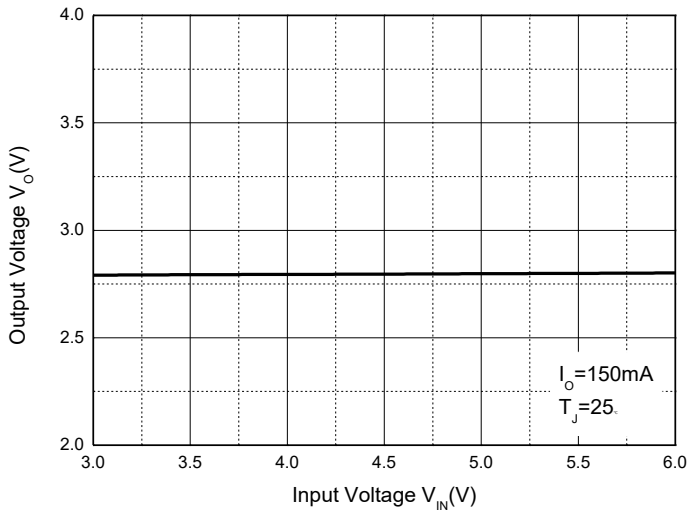

Output Voltage vs. Temperature

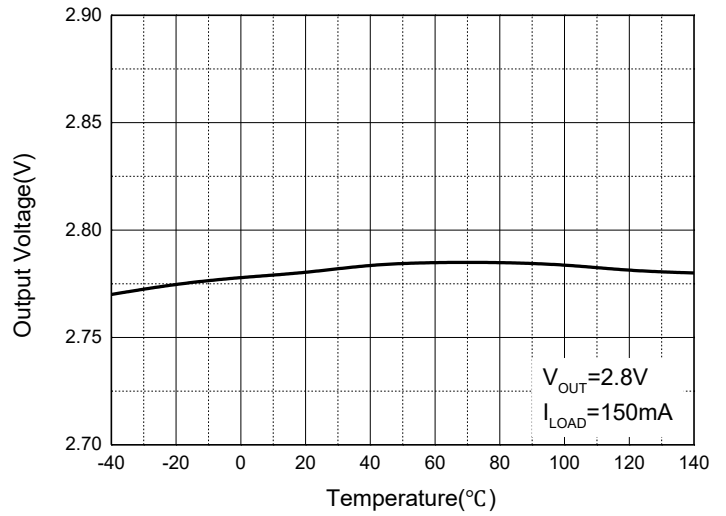

Quiescent Current

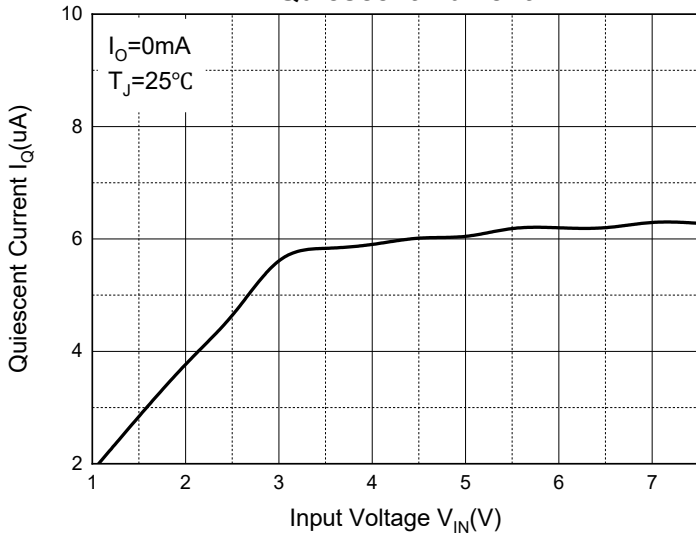

Current Cut-off Grid Voltage

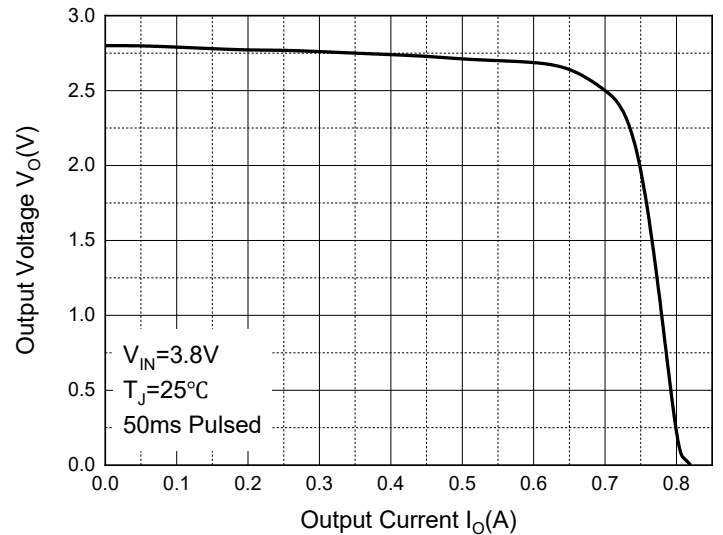

Dropout Voltage vs. Load Current

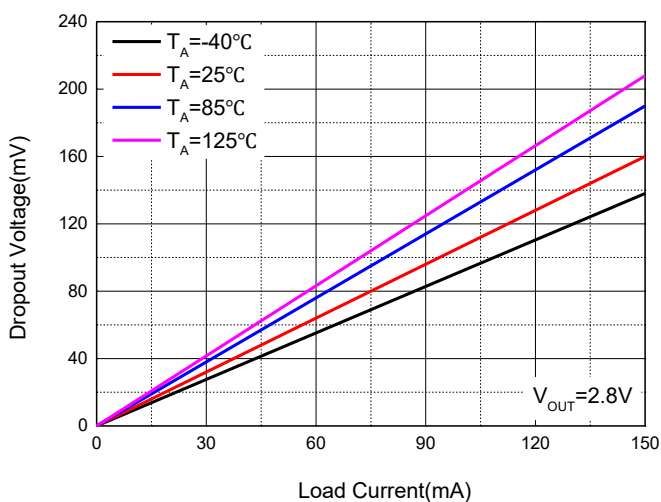

PSRR vs. Frequency

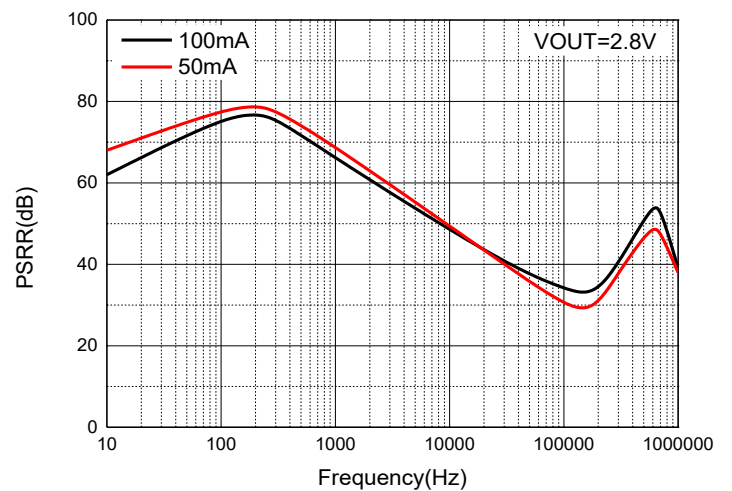

SOT-23-3L Package Outline Dimensions

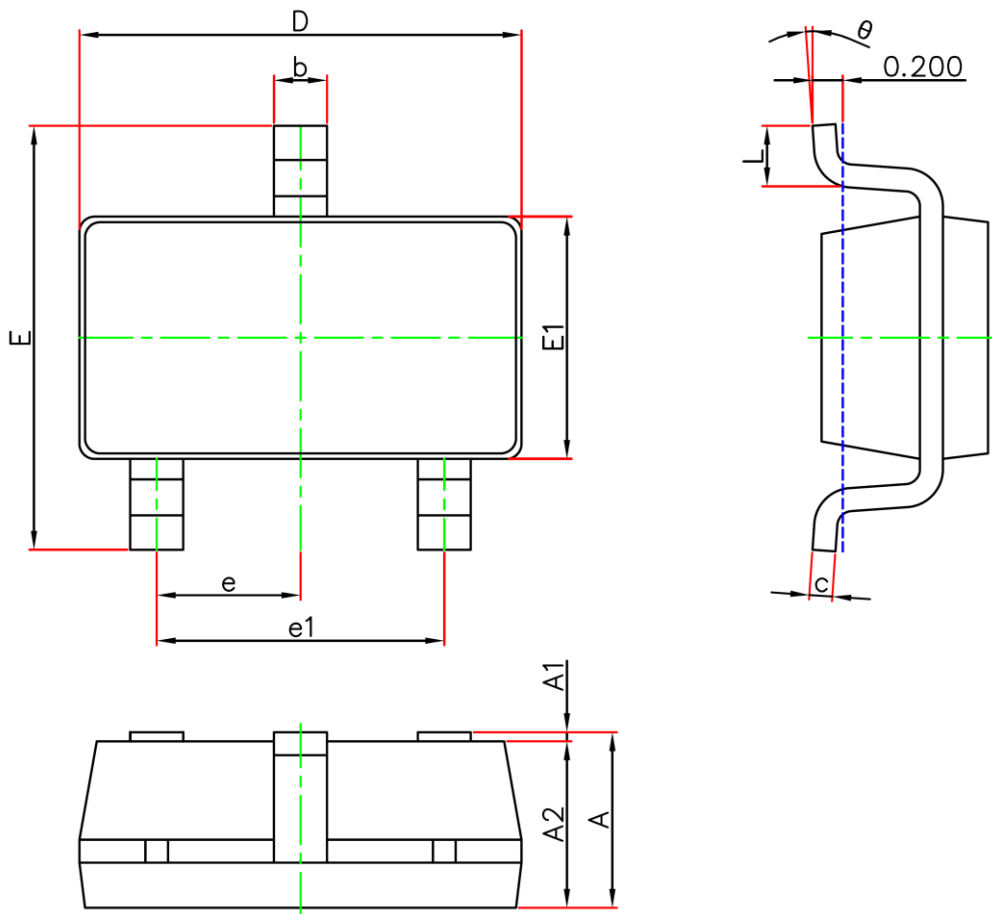

Symbol	Dimensions In Millimeters		Dimensions In Inches	
	Min.	Max.	Min.	Max.
A	1.050	1.250	0.041	0.049
A1	0	0.150	0.000	0.006
A2	1.050	1.250	0.041	0.049
b	0.300	0.500	0.012	0.020
c	0.100	0.200	0.004	0.008
D	2.820	3.020	0.111	0.119
E	2.650	2.950	0.104	0.116
E1	1.500	1.700	0.059	0.067
e	0.950TYP		0.037TYP	
e1	1.800	2.000	0.071	0.079
L	0.300	0.600	0.012	0.024
θ	0°	8°	0°	8°

SOT-23-5L Package Outline Dimensions

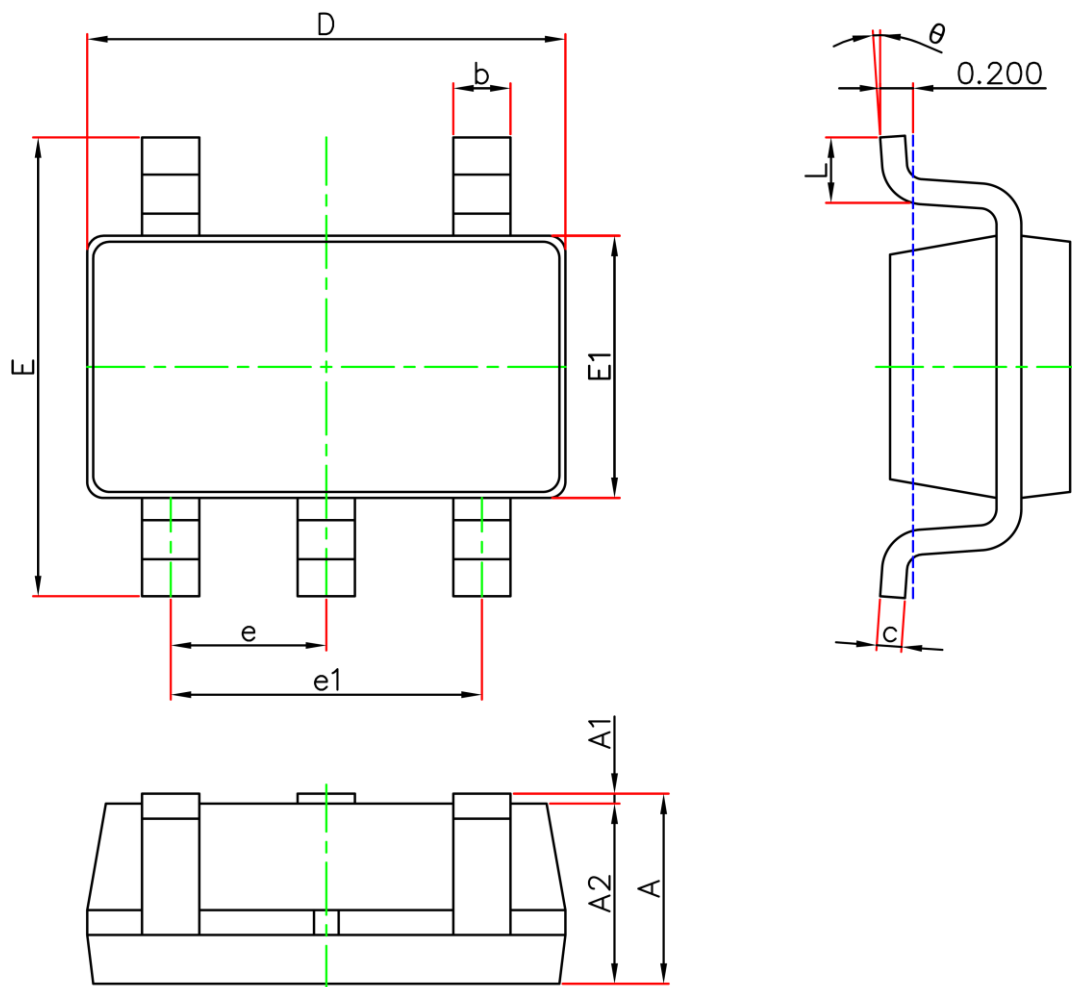

Symbol	Dimensions In Millimeters		Dimensions In Inches	
	Min.	Max.	Min.	Max.
A	1.050	1.250	0.041	0.049
A1	0	0.150	0.000	0.006
A2	1.050	1.250	0.041	0.049
b	0.300	0.500	0.012	0.020
c	0.100	0.200	0.004	0.008
D	2.820	3.020	0.111	0.119
E	2.650	2.950	0.104	0.116
E1	1.500	1.700	0.059	0.067
e	0.950TYP		0.037TYP	
e1	1.800	2.000	0.071	0.079
L	0.300	0.600	0.012	0.024
θ	0°	8°	0°	8°

DFN1*1-4L Package Outline Dimensions

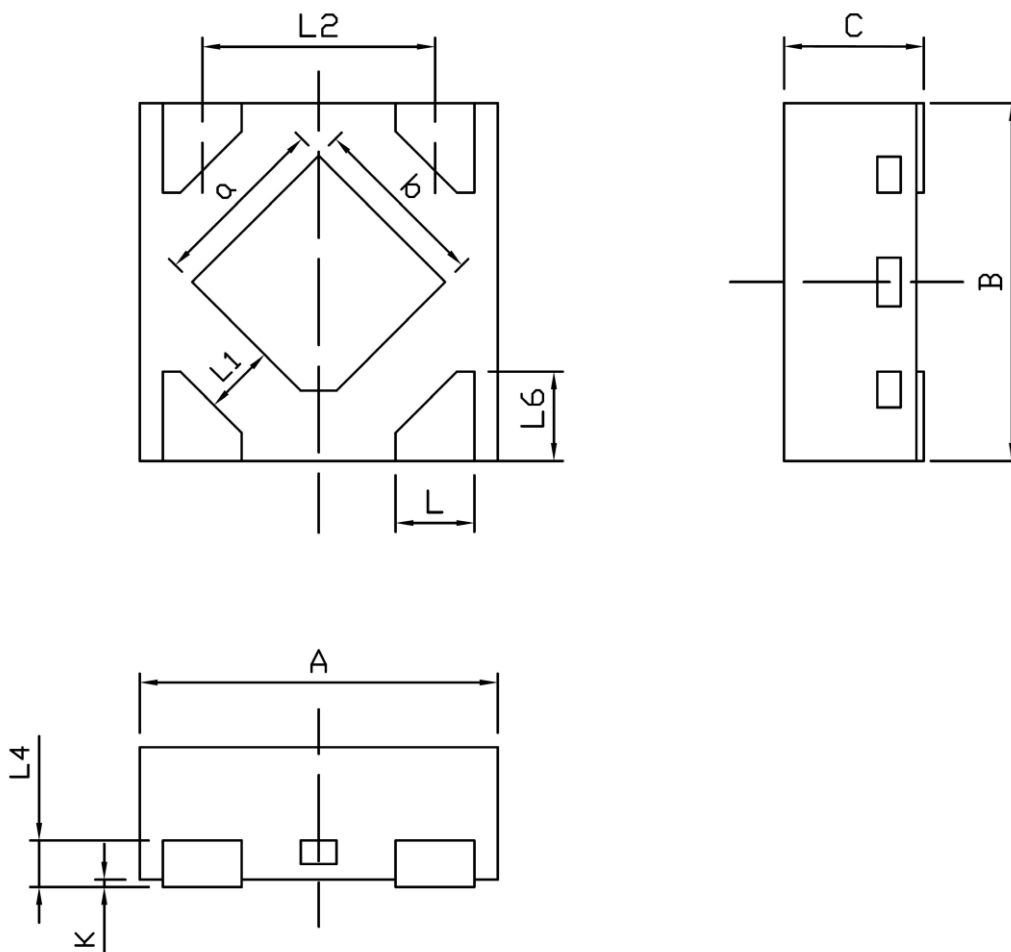

Symbol	Dimensions In Millimeters		Dimensions In Inches	
	Min.	Max.	Min.	Max.
A	0.950	1.050	0.037	0.041
B	0.950	1.050	0.037	0.041
C	0.340	0.400	0.013	0.016
L	0.150	0.250	0.006	0.010
L1	0.150MIN		0.006MIN	
L2	0.650BSC		0.026BSC	
L4	0.127REF		0.005REF	
L6	0.200	0.300	0.008	0.012
K	0.000	0.050	0.000	0.002
a	0.380	0.580	0.015	0.023
b	0.380	0.580	0.015	0.023

SOT-89-3L Package Outline Dimensions

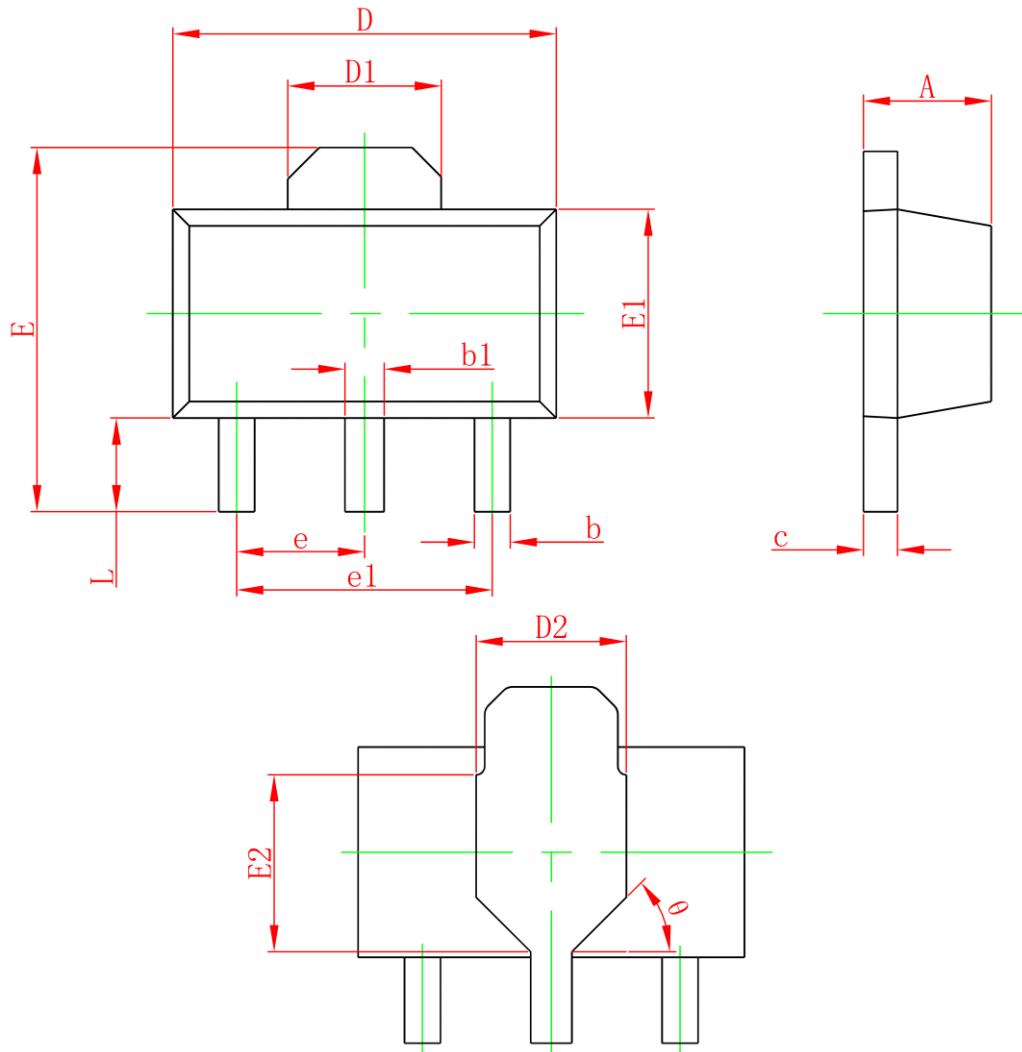

Symbol	Dimensions In Millimeters		Dimensions In Inches	
	Min.	Max.	Min.	Max.
A	1.400	1.600	0.055	0.063
b	0.320	0.520	0.013	0.020
b1	0.380	0.580	0.015	0.023
c	0.350	0.500	0.014	0.020
D	4.400	4.600	0.173	0.181
D1	1.650REF		0.065REF	
D2	1.650	1.850	0.065	0.073
E	3.900	4.400	0.154	0.173
E1	2.300	2.600	0.091	0.102
E2	1.900REF		0.075REF	
e	1.500TYP		0.059TYP	
e1	3.000TYP		0.118TYP	
L	0.900	1.200	0.035	0.047
θ	45°		45°	

SOT-89-5L Package Outline Dimensions

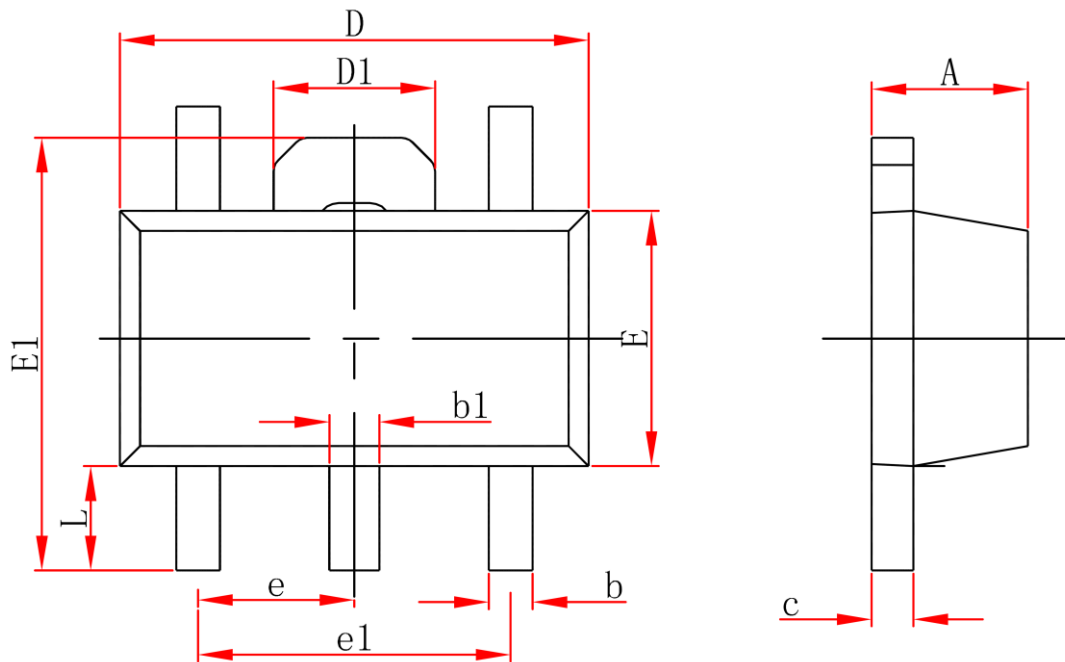

Symbol	Dimensions In Millimeters		Dimensions In Inches	
	Min.	Max.	Min.	Max.
A	1.400	1.600	0.055	0.063
b	0.320	0.520	0.013	0.020
b1	0.380	0.580	0.015	0.023
c	0.350	0.500	0.014	0.020
D	4.400	4.600	0.173	0.181
D1	1.650REF		0.065REF	
E	2.300	2.600	0.091	0.102
E1	3.900	4.400	0.154	0.173
e	1.500TYP		0.059TYP	
e1	3.000TYP		0.118TYP	
L	0.900	1.200	0.035	0.047